

STEAMIST®

ASME Code Blowdown Tank

Product Number: 68007

The ASME Code Blowdown Tank permits draining of hot boiler water into the tank for cooling before it is dumped into drainage system. This allows the HC blowdown system to comply with codes that prohibit the discharge of water exceeding 140°F.

Blowdown Tank Information

The Steamist Blowdown Tank is constructed in accordance with Section VIII, ASME Boiler and Pressure Vessel Code. The units are monitored through all steps of fabrication, pressure tested, checked for leaks and structural integrity by an independent third party to ensure compliance with the code. They are intended for professional installation and operation. If you are not familiar with the proper use and installation of a steam generator blowdown system seek professional help.

Installation

NOTE: Please make sure that the HC Series steam generator is elevated so that its drain outlet is above the Blowdown Tank inlet. (It is recommended to use the optional Steamist stand for this application.)

1. Connect the HC Series steam generator in accordance with these instructions and with local code requirements. See Figure 2. The blowdown vent must be piped to a safe place of discharge to prevent injury or property damage. It is recommended that the Blowdown Tank discharge and drain should be connected to an indirect waste. Check local and state codes concerning the maximum allowable temperature for blowdown discharge to a public sewer system. The National Board Standard is a maximum of 140 degrees F.
2. All piping, fittings and valves must be rated in accordance with ASME Code B31 – Power Piping. All piping and nipples used must be schedule 80.
3. Never reduce the size of the Blowdown Tank vent piping. The vent must be piped full size for the entire length and must terminate at a safe place of discharge per local codes.

Blowdown Procedure

Blowdowns are done to remove excessive amounts of dissolved solids from the boiler water. Blowdown is automatically done (with the optional automatic blowdown valve) at the end of the working day. Blowdown can also be done manually. Pressure in the boiler is required to conduct the blowdown.

Figure 1 - ASME Code Blowdown Tank

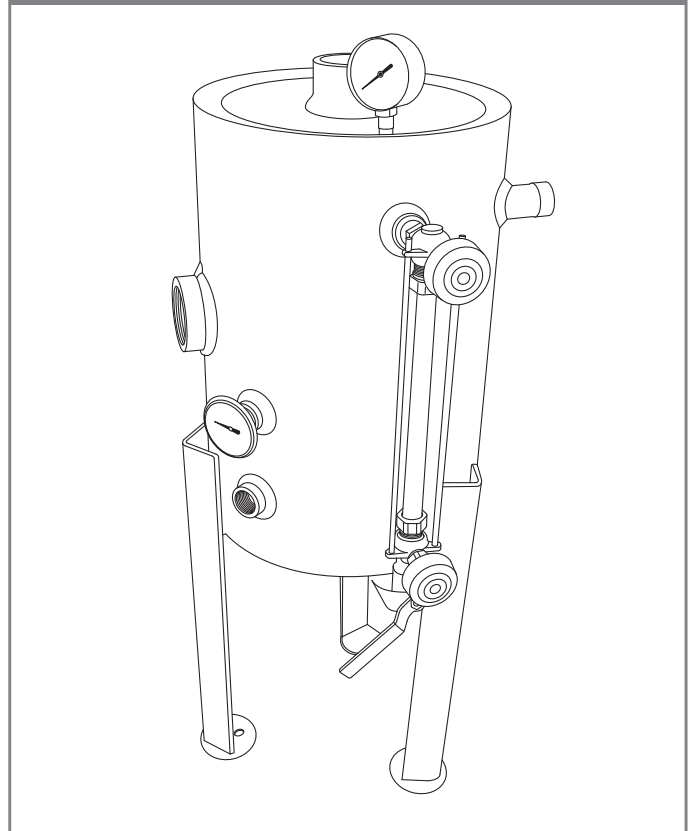

IMPORTANT: Before using the blowdown tank for the first time or operating the steam generator equipped with an automatic blowdown valve, the Blowdown Tank must be filled with cold water to the center of the gauge glass level. Open the cold water supply valve until the level is about half way up the blowdown tank gauge glass. The water in the tank is intended to mix with the hot boiler water and temper it before it goes down the drain. After a blowdown cycle the Blowdown Tank must cool to room temperature before another blowdown cycle.

Automatic blowdown is done at the end of the day or at the scheduled OFF mode on the Steamist DCCP digital control. When first entering OFF mode, the steam valves will deactivate and the generator will continue to maintain normal operating pressure of about 3-5 PSI. After 5 minutes the generator will shut down and the drain will open. Boiling water will exit under pressure and cold water will enter the generator to help flush the generator. After 2 minutes the drain will close and the generator will

refill. After a total of 7 minutes the generator is ready to start a new cycle. If the facility is operated 24 hours a day, a 7 minute OFF mode should be programmed in to allow for a proper blowdown cycle. In areas where the water is hard, a second drain cycle can be programmed by adding an extra 7 minute off mode program. The operator must make sure there is adequate time in between blowdown cycles to allow the Blowdown Tank to cool to room temperature.

Manual Blowdown should be done at the end of each operating day. While the Steamist HC Series steam generator is still on and operating turn the steam switches to the off position allowing the generator to return to normal operating pressure of 3-5 PSI. Open the drain valve on the steam generator. Once the water has emptied the boiler and the pressure drops to zero turn the steam switches back on and close the drain valve on the steam generator and allow it to refill. Once it is refilled the steam generator can be shut down for the night.

Maintenance

Twice a year the Blowdown Tank should be cleaned. Boilers connected to the tank should be secured and cooled prior to conducting the cleaning and inspection of the tank. The isolation valve(s) to the boilers should be shut. Open the fresh water supply to the tank and allow water to flow through the tank for several minutes. Stop fresh water flow. Open the drain and allow as much water as possible to drain out of the unit. Shut the drain.

Remove the gauge on the top of the unit and add 16 ounces of scale remover such as SubLime or CLR. Fill the unit with water and allow to sit for about one hour.

Run water through the unit for five minutes. Replace the gauge on top of the unit.

If the tank is equipped with a gauge glass it should be cleaned and check for leaks. Replace the glass and seals if evidence of leaks are found.

Check the tank vent to make sure that it is clear to the atmosphere.

Figure 2

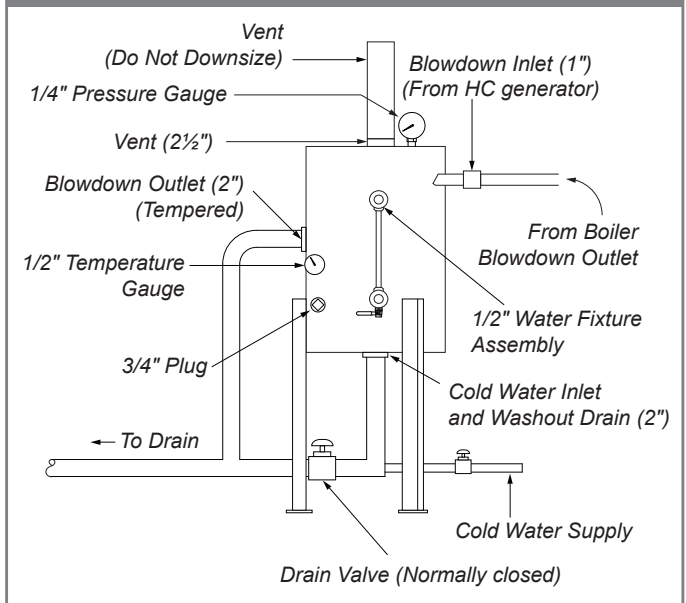
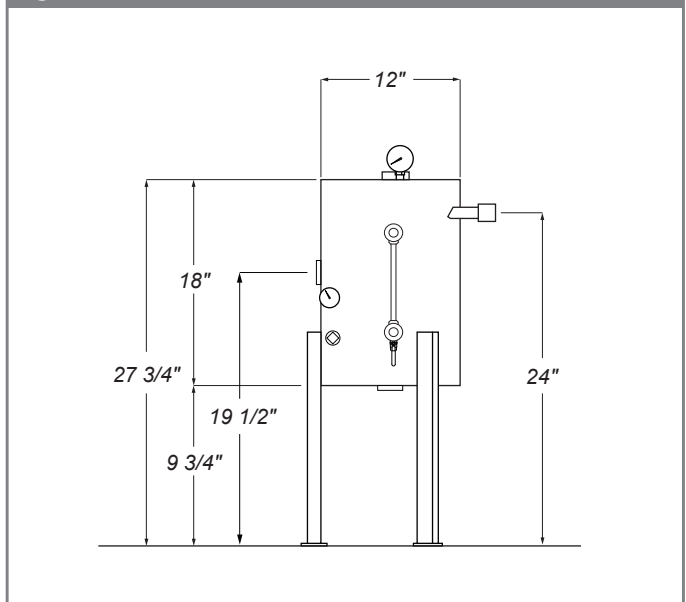

Figure 3



NOTE: The Steamist Blowdown Tank design incorporates a water valve at the cold water inlet which permits the operator to introduce cold water from the bottom to mix with the hot water blowdown in the tank. This reduces the outlet temperature to a level that makes it safe to discharge. If the tank is less than half full of water after the boiler is blowdown, cold tap water must be added to bring the water level to the halfway mark before the next blowdown.